

VP-100A-XXK[D;N;S]

LED Canopy 100W 13000lm

Features

- Integrated die-casting forming, with effective heat dissipation.
- IP65 Wet Location
- L70>50,000 Hours.
- ETL, cETL List.
- 5 Years Warranty.

Parameter

Model No.:	VP-100A-XXK[D;N;S]
Power Consumption:	100W
Input Voltage:	100-277Vac 50/60Hz
LED Type:	SMD3030
Luminous efficacy:	130lm/W
Lumens	13000lm
CRI;	80+
Color Temperature:	3000K, 4000K, 5000K, 5700K
Beam Angel:	120°
Power Factor:	>0.90
IP Rating	IP65 / Wet location
Working Temp.:	-20° C ~ 50° C
Storage Temp.:	-40° C ~ 70° C
Lifespan(L70):	>50,000 Hours
Finish:	White
Housing:	Die-Casting Aluminum
Cover:	Plastic
Installation:	Surface mounted, Conduit Mounted
Fixture Weight:	4kg(8.8lb)

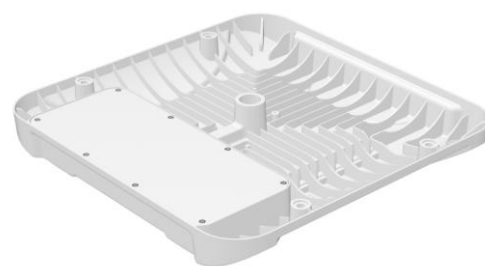

Photometrics

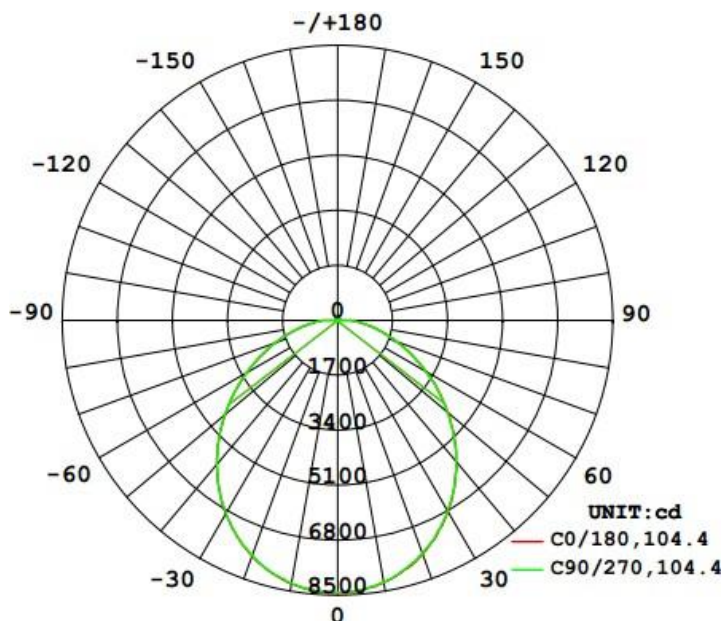

Dimension(mm)

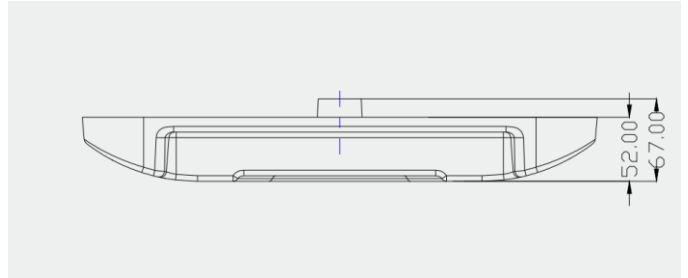
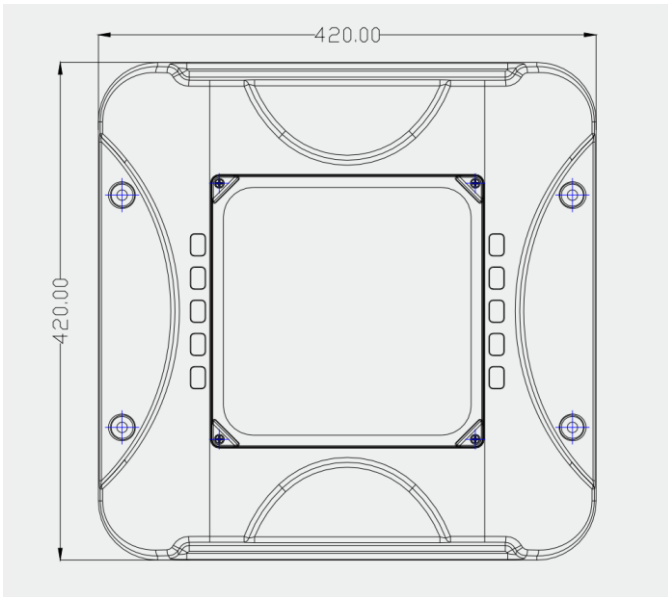

Packaging

Item	Q'ty/CTN	G. W.	CTN Size
VP-100A-XXK[D;N;S]	1	5kg(11lb)	47x47x15cm

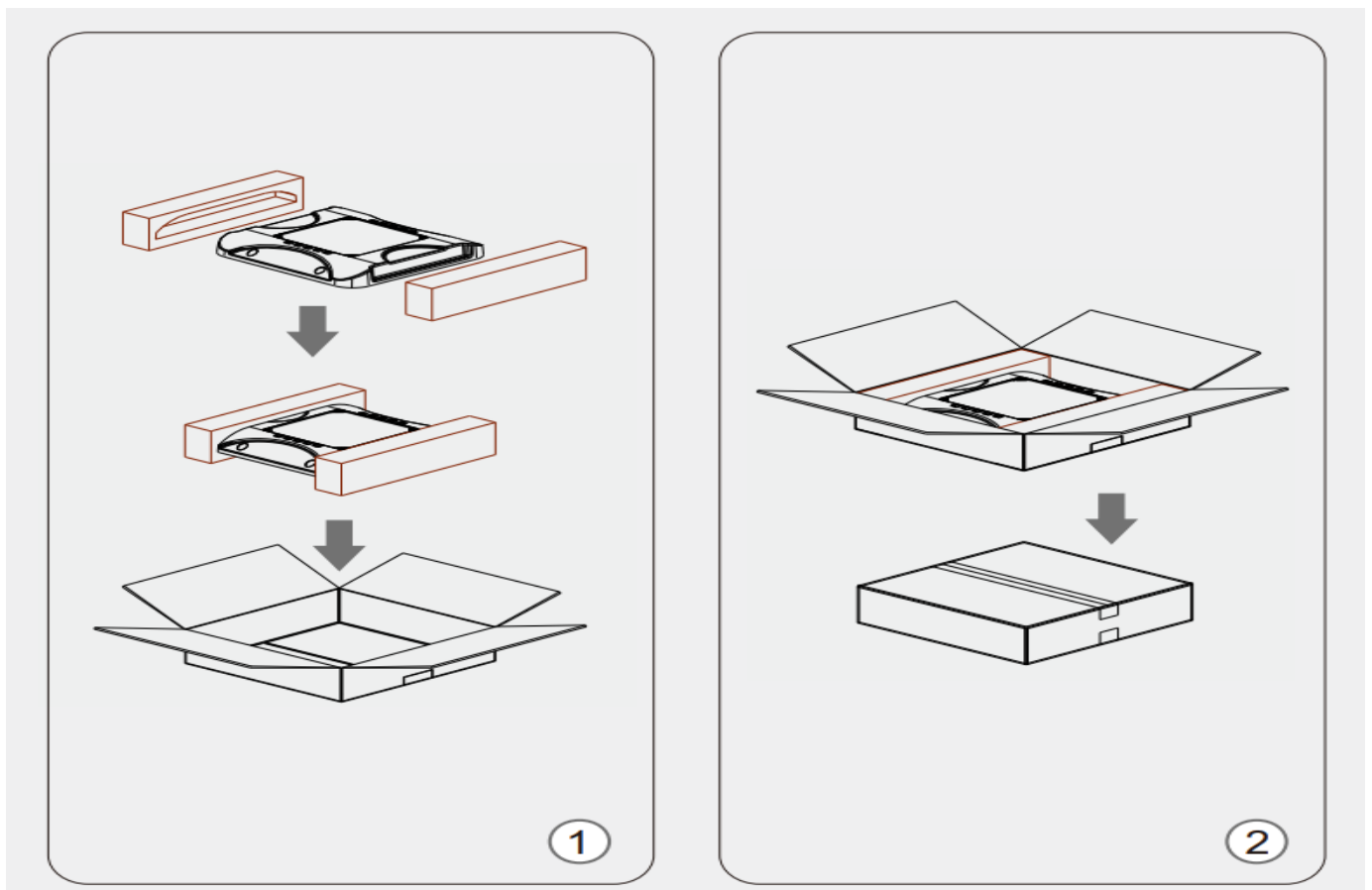

Shenzhen CGT Technology Co.,LTD.

Tel: 0086-755-22361751 Web: www.cgtled.com E-mail: info@cgtled.com
No.11,YuanHu Road Zhangbei Industrial Park,Longgang Dsistrict,Shenzhen,China